

MC9090-G

Quick Start Guide



BATTERY INSERTION

<http://www.symbol.com/mc9000> See User Guide for more information

Front View

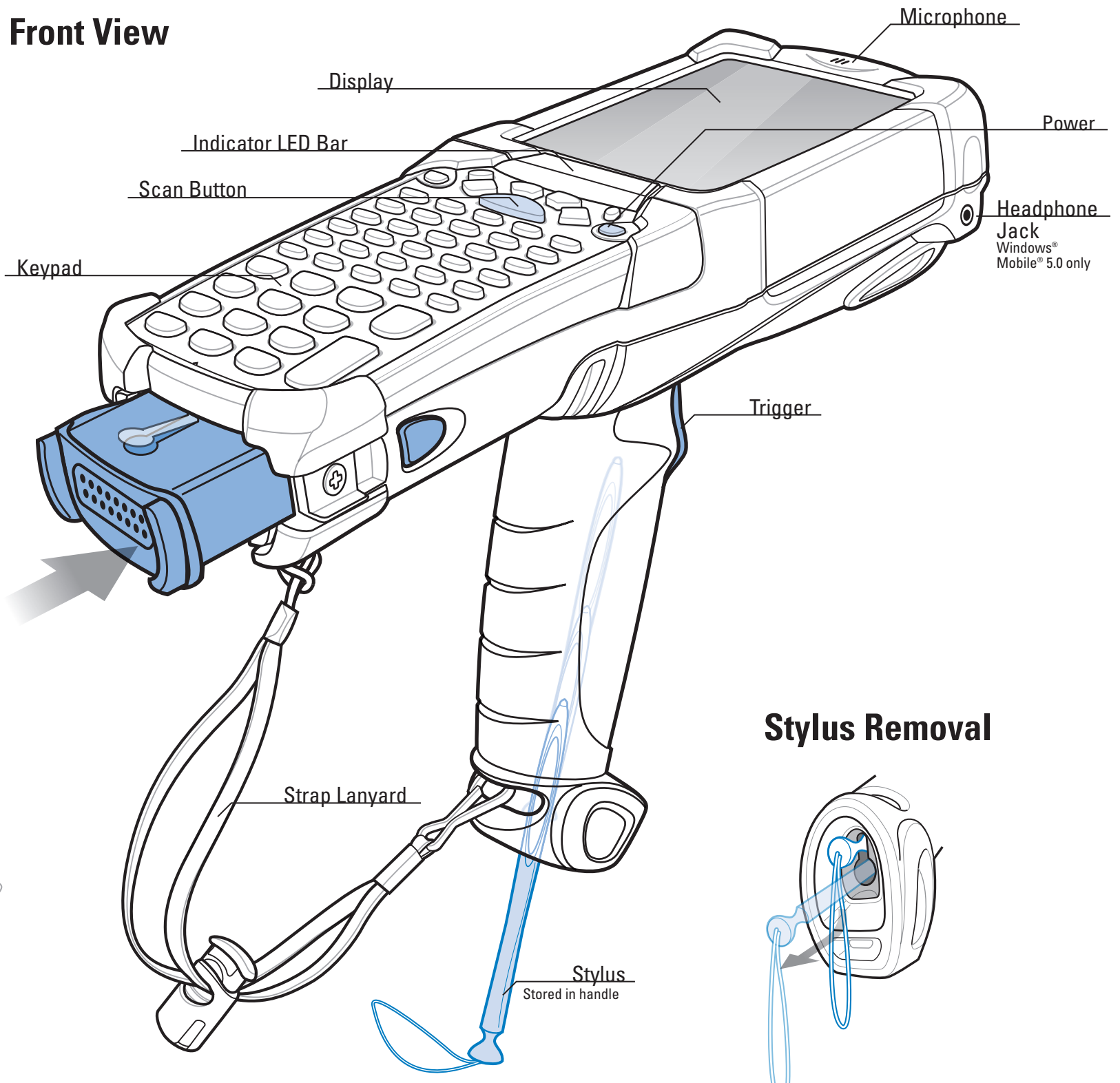

POST IN WORK AREA

Battery Removal

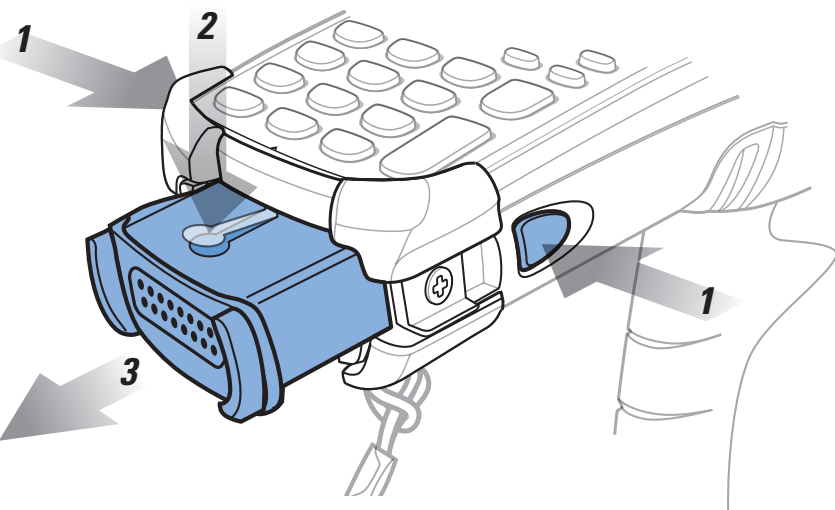

Stylus Removal

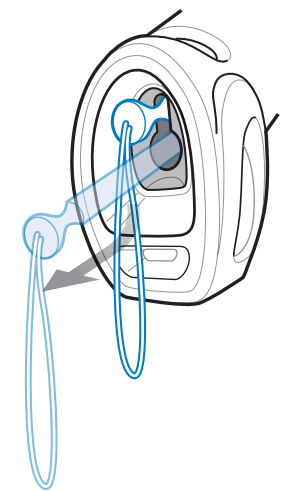

SNAP-ON ACCESSORY INSTALLATION

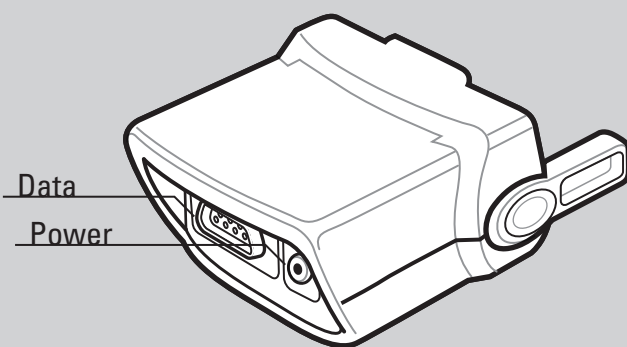
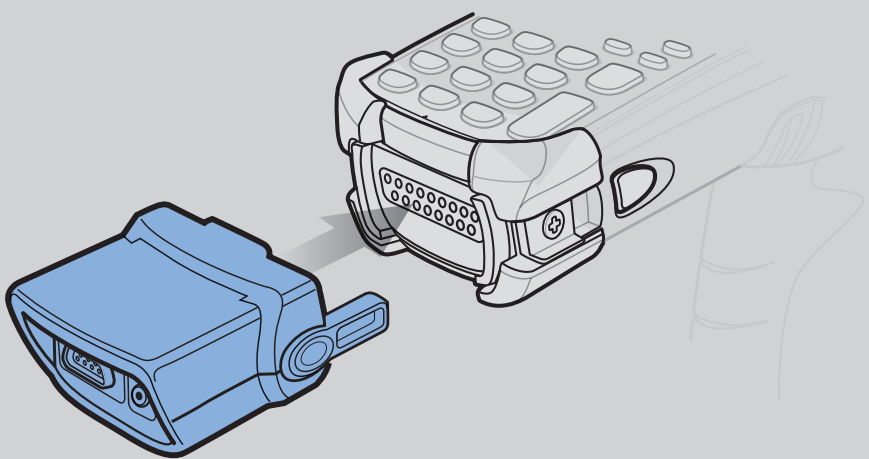

Cable Adapter Module

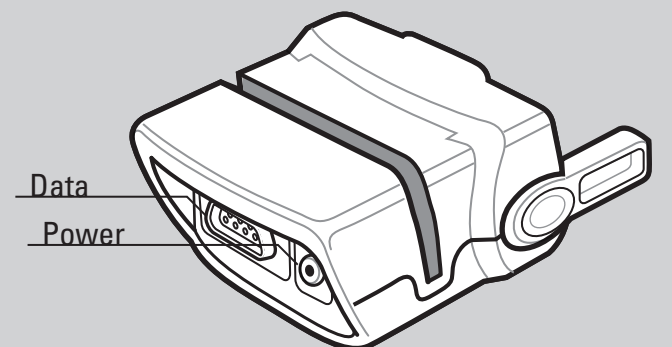

Data
Power

Magnetic Stripe Reader

CHARGING INSTRUCTIONS

⦿ = LED Indicator Location Slow Flash = Normal Charge Solid Amber = Full Charge Fast Flash = Charging Error

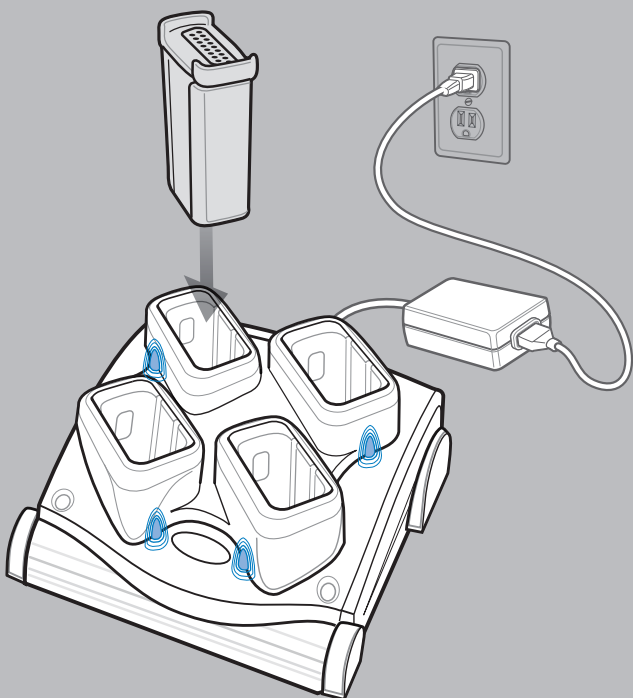

Four Slot Spare Battery Charger



Single Slot Serial/USB Cradle

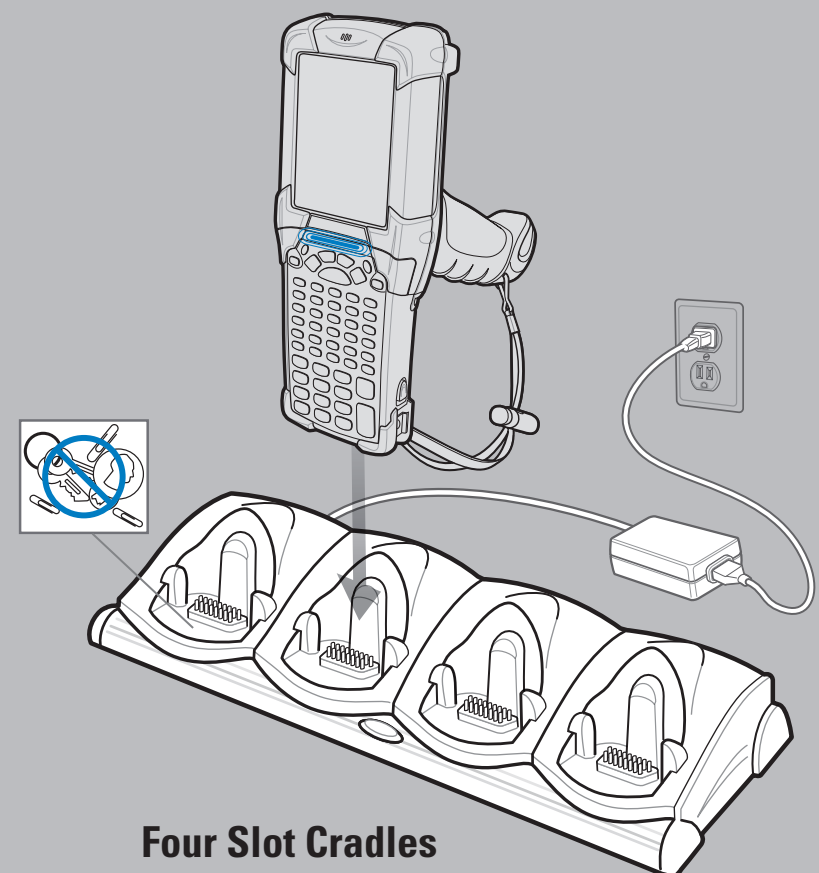

Four Slot Cradles
Charge-Only Cradle and Ethernet Cradle

OPTIMUM IMAGING AND SCANNING POSITIONS

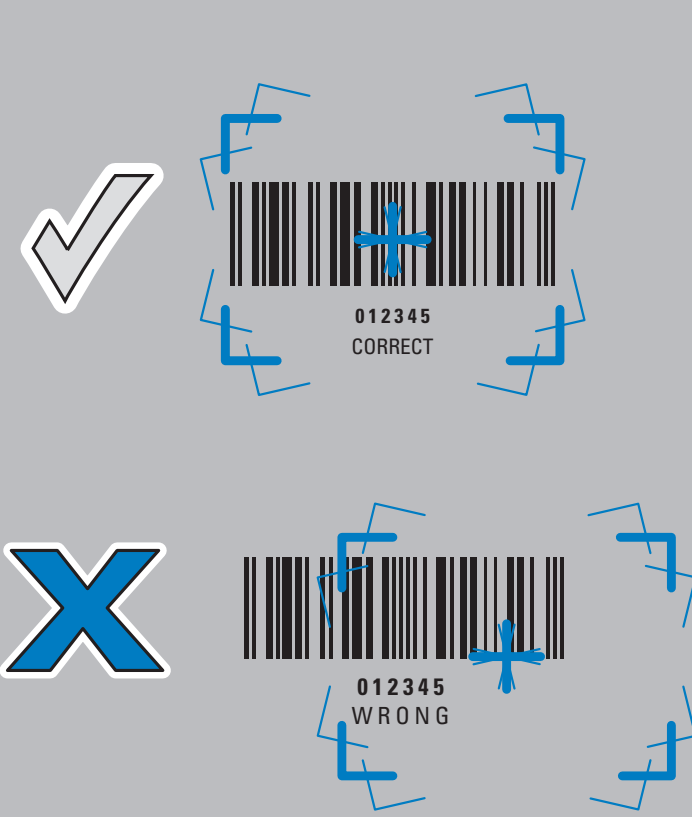
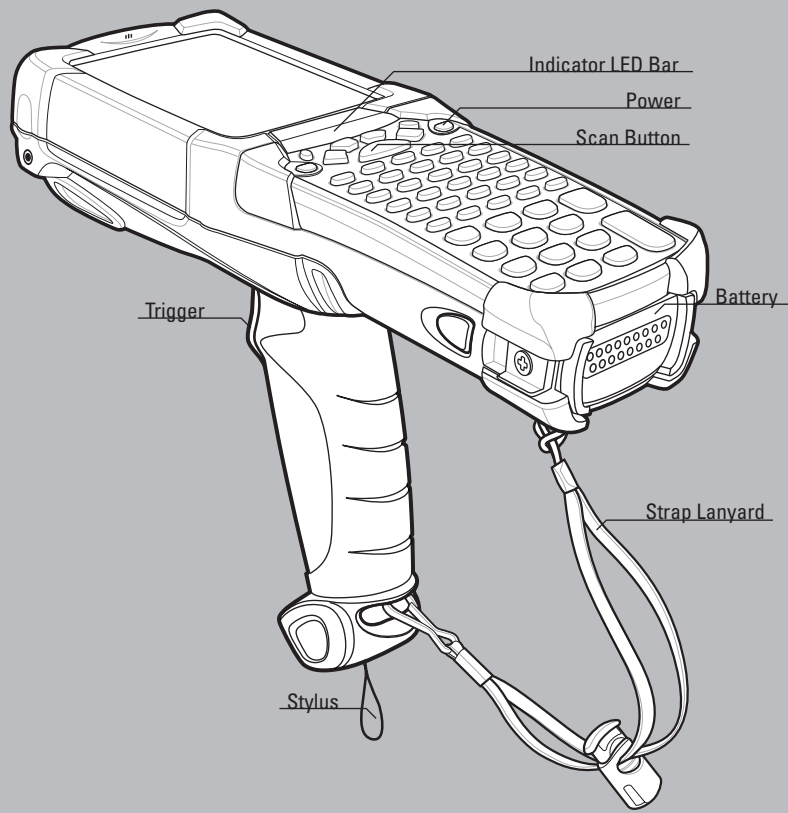

Scanning/Imaging

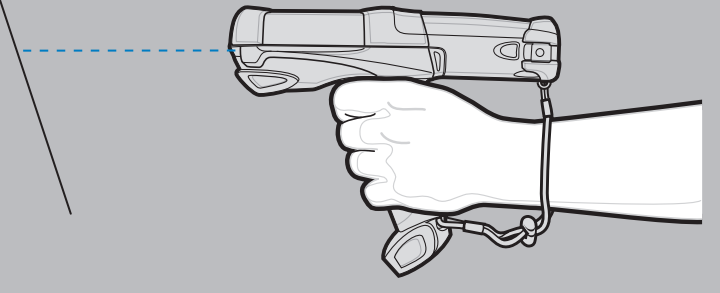

OPTIMUM UPRIGHT BODY POSTURE

AVOID EXTREME WRIST ANGLES

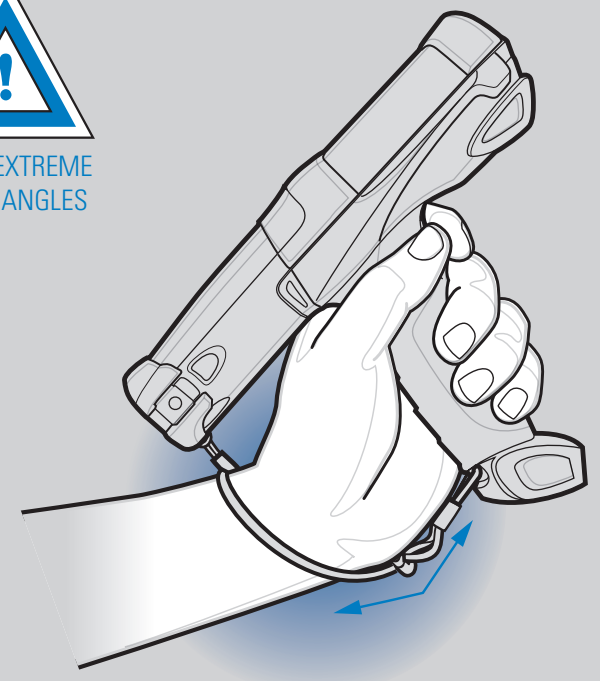
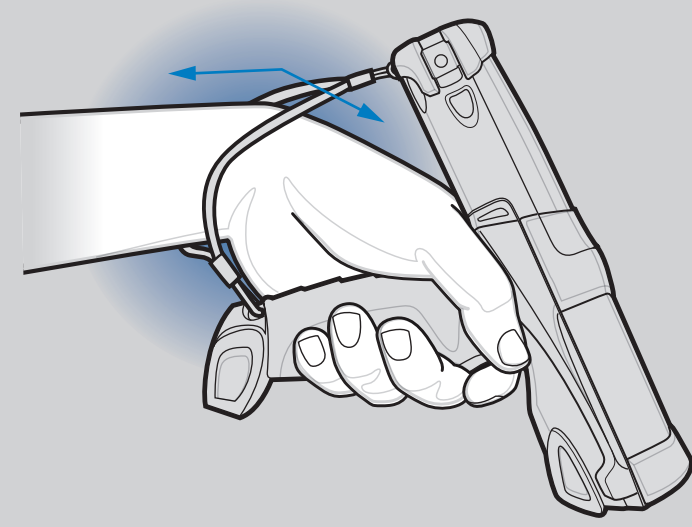
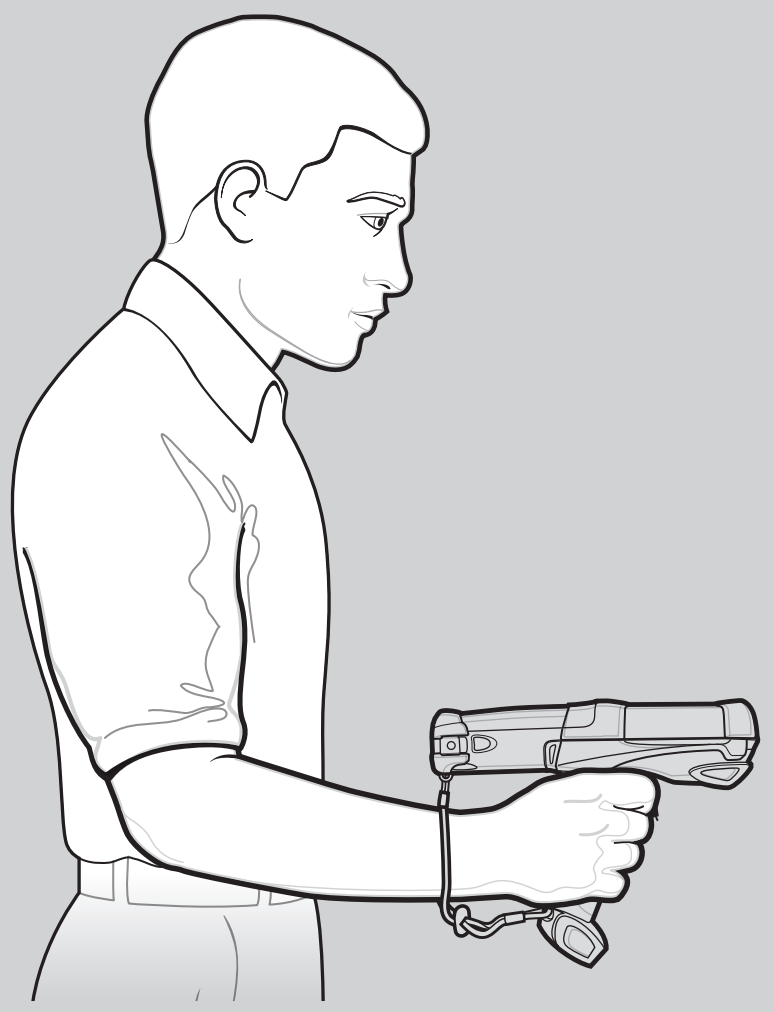

ALTERNATE LEFT AND RIGHT HANDS
TAKING BREAKS AND TASK ROTATION RECOMMENDED

OPTIMUM BODY POSTURE

Low Scanning

Alternate left and right knees

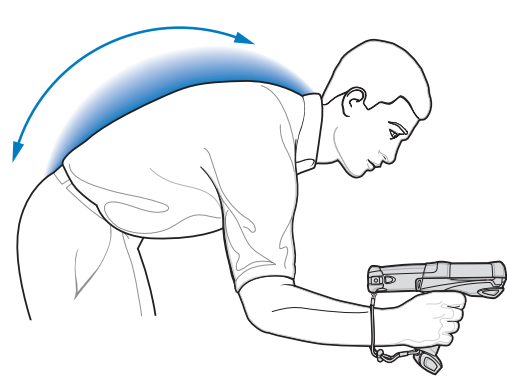

Alternate left and right hands



High Scanning

Use a ladder



Taking breaks and task rotation recommended

POST IN WORK AREA



MOTOROLA

One Motorola Plaza Holtsville, New York 11742-1300, USA
MOTOROLA and the Stylized M Logo and Symbol and the Symbol logo are registered in the U.S. Patent and Trademark Office. All other product or service names are the property of their respective owners.
© Motorola, Inc. 2007



72-72217-02 Rev. A - October 2007

<http://www.symbol.com/mc9000>

MC9090-G

Recommended Usage Guide